

CST - Construction Surveying
and Site Management

T018

Wednesday, 06/11/2013
8:30 - 11:30 AM

WORKFORCE DEVELOPMENT AUTHORITY

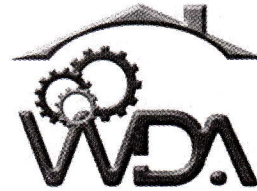

P.O. BOX 2707 Kigali, Rwanda Tel: (+250) 255113365

**ADVANCED LEVEL NATIONAL EXAMINATIONS, 2013,
TECHNICAL AND PROFESSIONAL TRADES**

EXAM TITLE: Construction Surveying and Site Management

OPTION: Construction (CST)

DURATION: 3hours

INSTRUCTIONS:

The paper contains **three (3)** parts :

Part I: Seventeen (17) questions, all **compulsory;** **55marks**

Part II: Five (5) questions, **Choose any three (3);** **30marks**

Part III: Three (3) questions, **Choose any one (1);** **15marks**

Part I. All the 17 questions are compulsory. 55marks

01. What is surveying? **3marks**
02. What is the objective of surveying? **3marks**
03. Distinguish between a map and a plan. **3marks**
04. Give primary classification of survey. **3marks**
05. What are general principles of surveying? **3marks**
06. What is shrunk scale? **3marks**
07. What are different activities of a surveyor? **3marks**
08. What is chain survey? **3marks**
09. What is a well-conditioned triangle? **3marks**
10. Name 5 devices that may be employed in taking linear measurements. **3marks**
11. Name the classification of survey based on the nature of survey field. **3marks**
12. What do you understand by the term leveling? **3marks**
13. What is the necessity of information given by leveling? **3marks**
14. Give the stepwise procedure for the temporary adjustment of a Theodolite. **3marks**
15. A plot of land measures 30cm x 60cm on a map drawn to scale 1cm = 50m. What will be the area of the map when placed on a topographical map drawn to a scale of 1cm = 60m? **3marks**
16. What does construction worksite organization mean? **5marks**
17. What are the temporary facilities in the construction jobsite management? **5marks**

Part II. Choose and answer any three (3) questions. 30marks

18. A, B, C and D are points on line AD on a sloping ground. The distances between the points are measured by chain and the corresponding angles of slopes are given below. Calculate the horizontal distances AD. **10marks**

Line	Length	Angle of slope
AB	75m	5°
BC	30m	10°
CD	60m	8°

19. The back sight and fore sight at points C and D are 3.565m and 2.865m respectively. Find the difference of level between C and D. State also if this is fall or rise from C to D. **10marks**
20. Figure 1.1 shows part of an embankment and its dimensions. What is its volume? **10marks**

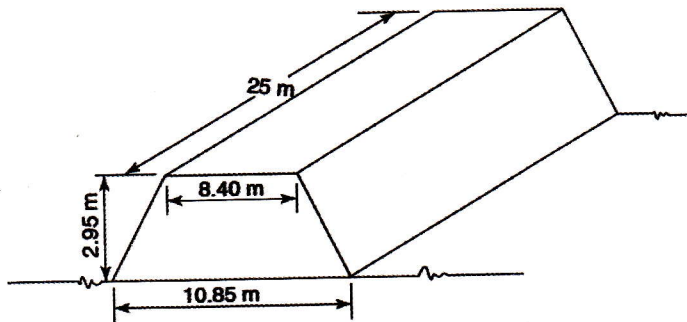

Figure 1.1

21. The gradient of a road is 9%. Find the vertical rise/fall if the length of the road is 2450m. **10marks**
22. What is jobsite layout plan? **10marks**

Part III. Choose and answer any one (1) question. 15marks

23. List the steps of materials procurement process in the construction site management. **15marks**
24. A surveyor, 100m from a building, measures the angle of elevation to the top of a building to be 40° (Figure 2.1). If the height of the instrument is 1.400m and the ground between the surveyor and the building is level, find the height of the building. **15marks**

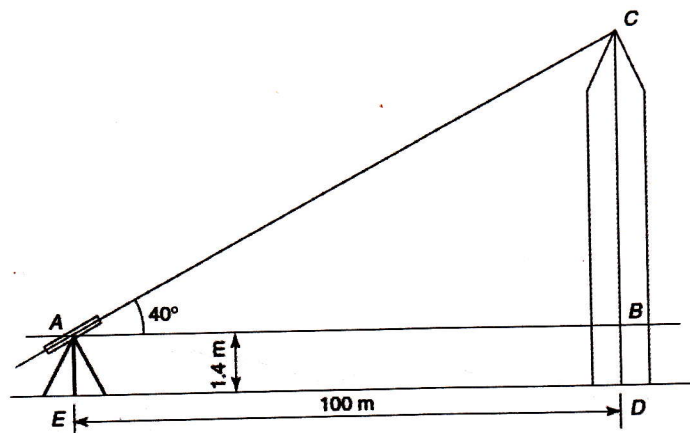

Figure 2.1

25. Jane, standing on the 15th floor of a building, looks at her car parked on the nearby road. Find the angle of depression if the other details are as shown in Figure 3.1. **15marks**

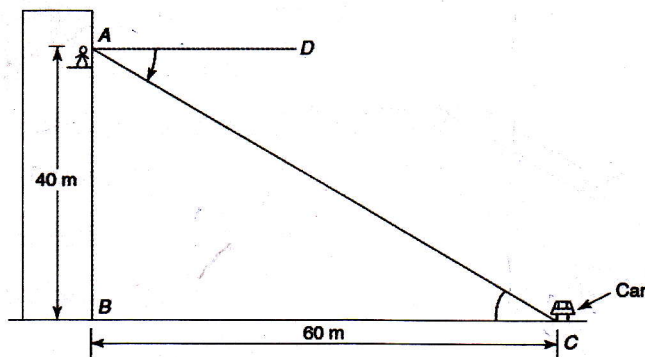

Figure 3.1